

Antaira Technologies

LNX-2602G-SFP Series

26-Port Industrial Gigabit Unmanaged Ethernet Switch, with 24*10/100/1000Tx and 2* Gigabit Combo Ports (2*10/100/1000Tx RJ45 and 2*100/1000 SFP Slots)

Quick Installation Guide

Version 1.0
(September 2022)



Package Check List

The package contains the following items:

- 1 – Quick Installation Guide
- 1 – LNX-2602G-SFP(-T)
- 1 – Rack Mounting Brackets and Screws
- 1 – AC Power Cord Cable
- 1 – Dust Cover Set

Front Panel Layout

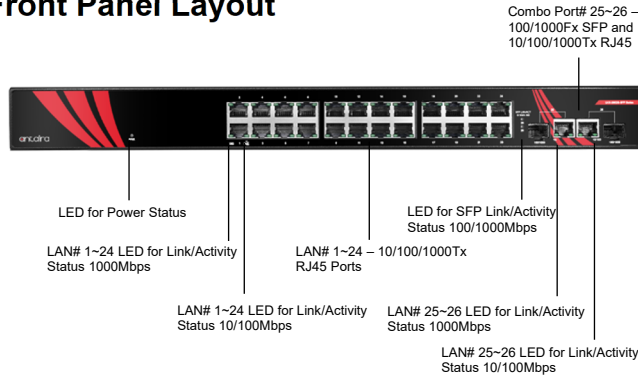

Back Panel View

LNX-2602G-SFP Series back panel is equipped with one IEC 320 C14 type power socket and a power switch.



Product Overview

System Interface/Performance

- RJ45 port supports the auto MDI/MDI-X function
- Embedded 24*10/100/1000Tx RJ45 Ethernet ports and 2*Gigabit combo ports (2*10/100/1000Tx RJ45 and 2*100/1000 SFP slots)
- Store-and-forward switching architecture
- 8K MAC address table
- Jumbo frame supports up to 9.6Kbytes

Power Input & Connection

- AC 100-240VAC / 50-60Hz

Operating Temperature

- Standard Operating Temperature Model: -10°C to 70°C
- Extended Operating Temperature Model: -40°C to 75°C

Case/Installation

- IP40 Protection
- 1U Rackmount Design

Safety Precaution

AC voltage should be protected by a fuse or circuit breaker.

LED Indicators

LED	Color	Description	
PWR	Green	On	Power input is active
		Off	Power input is inactive
Combo Port SFP LNK/ACT (Port 25-26)	Green	On	Connected to network, 1000Mbps
		Flashing	Networking is active
		Off	Not connected to network
	Amber	On	Connected to network, 100Mbps
		Flashing	Networking is active
		Off	Not connected to network
Combo Port LAN (Port 25-26)	Green	On	Connected to network, 1000Mbps
		Flashing	Networking is active
		Off	Not connected to network
Combo Port LAN (Port 25-26)	Green	On	Connected to network, 10/100Mbps
		Flashing	Networking is active
		Off	Not connected to network
LAN Port 1-24	Green	On	Connected to network, 1000Mbps
		Flashing	Networking is active
		Off	Not connected to network
LAN Port 1-24	Green	On	Connected to network, 10/100Mbps
		Flashing	Networking is active
		Off	Not connected to network

Quick Installation

Ethernet RJ45 Port (Auto MDI/MDIX)

RJ45 port is auto-sensing for 10Base-T, 100Base-TX or 1000Base-TX device connections. Please follow the wiring pin assignment table below for the Ethernet port installation.

RJ45 Ethernet Port Pin Outs				
Pins	T568A Color	T568B Color	10/100 Base-T(X)	1000 Base-T
1	White/Green	White/Orang	Rx+	TP0+
2	Green	Orange	Rx-	TP0-
3	White/Orange	White/Green	Tx+	TP1+
4	Blue	Blue	unused	TP2+
5	White/Blue	White/Blue	unused	TP2-
6	Orange	Green	Tx-	TP1-
7	White/Brown	White/Brown	unused	TP3+
8	Brown	Brown	unused	TP3-

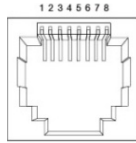

SFP Slots

The Small Form-Factor Pluggable (SFP) is a compact optical transceiver used in optical communications.

Please follow the steps below for connecting the SFP and LC cable:

1. Insert the SFP transceiver module into the SFP slot as shown below in *Figure 1* (Please be noted that the triangle mark is at the bottom of the SFP slot). *Figure 2* shows the SFP transceiver module was inserted.

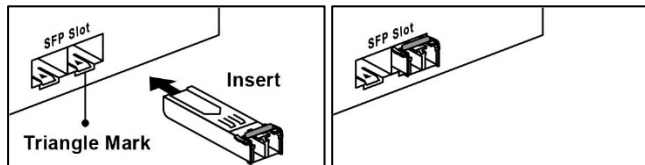

Figure 1

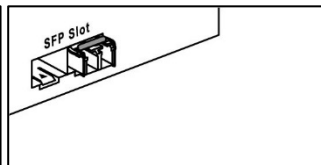

Figure 2

2. Insert the fiber cable of the LC connector into the transceiver as shown below in *Figure 3*.

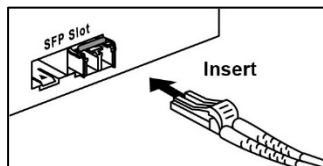

Figure 3

Power Wiring

Please follow the below steps:

1. Turn the power switch into off position.
2. Insert the AC power cable into the socket as shown in *Figure 4*.
3. Turn the power switch on.



Figure 4

Industrial Switch Mounting

The switch comes with a rack-mounted kit can be mounted in an EIA standard size, 19-inch rack. It can be placed in a wiring closet with other equipment.

Perform the following steps to rack-mount the switch.

1. Position one plate to align with the holes on one side of the hub and secure it with the smaller plate screws. Then, attach the remaining plate to the other side of the switch.

2. After attaching both mounting plates, position the switch in the rack by lining up the holes in the plates with the appropriate holes on the rack. Secure the switch to the rack with a screwdriver and the rack-mounting screws.



***Note:** For proper ventilation, allow at least 4 inches (10 cm) of clearance on the front and 3.4 inches (8 cm) on the back of the switch. This is especially important for enclosed rack installation.

Field Maintenance and Service

- If the device requires servicing of any kind, the user is required to disconnect and remove it from its mounting. The initial installation should be done in a way that makes this as convenient as possible.
- Voltage/Power lines should be properly insulated as well as other cables. Be careful when handling them so as to not trip over it.
- Do not under any circumstance insert foreign objects of any kind into the heat dissipation holes located in the different faces of the device. This may not only harm the internal layout, but might cause harm to user as well.
- Do not under any circumstance open the device for any reason. Please contact your dealer for any repair needed or follow the instructions within the manual.

Warranty Policy

Warranty Conditions

Products supplied by Antaira Technologies are covered in this warranty for sub-standard performance or defective workmanship. The warranty is not, however, extended to goods damaged in the following circumstances:

- (a) Excessive forces or impacts
- (b) War or an Act of God: wind storm, fire, flood, electric shock, earthquake
- (c) Use of unqualified power supply, connectors, or unauthorized parts/kits
- (d) Replacement with unauthorized parts

RMA and Shipping Costs Reimbursement

Customers shall always obtain an authorized "RMA" number from Antaira before shipping the goods for repair or replacement.

- Within the warranty period (based on the invoice date), all parts and labor are free of charge to the customers.
- Customers are required to be responsible for the cost of parts and labor, if the products are out of warranty.
- For RMA service, customers are responsible for the shipping expense for shipping the RMA unit(s) to Antaira; and Antaira will be responsible for the shipping expense by ground service for the return repair/replace unit(s) back to customers.

Limited Liability

Antaira would not be held responsible for any consequential losses from using Antaira's product.

Warranty Period

5-Year Warranty

Antaira's Customer Service and Support

- Antaira's Technical Service & Support Centers:
 - + 844-268-2472 (Antaira US Headquarter)
 - + 48-22-862-88-81 (Antaira Europe Office)
 - + 886-2-2218-9733 (Antaira Asia Office)
- Antaira's Web Sites & Repair/Support Emails:
 - www.antaira.com / support@antaira.com
 - www.antaira.eu / info@antaira.eu
 - www.antaira.com.tw / info@antaira.com.tw

***Any changes will be announced on the Antaira website.#**